

MITSUBISHI IGBT MODULES  
**CM450DX-24A**

HIGH POWER SWITCHING USE

**CM450DX-24A**



- IC ..... 450A
- VCES ..... 1200V
- Dual
- Flatbase Type / Insulated Package / Copper (non-plating) base plate
- RoHS Directive compliant

**APPLICATION**

General purpose Inverters, Servo Amplifiers, Power supply, etc.

**OUTLINE DRAWING & CIRCUIT DIAGRAM**

Dimensions in mm

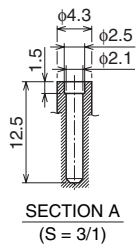
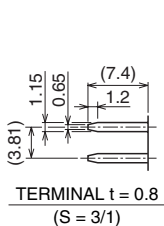
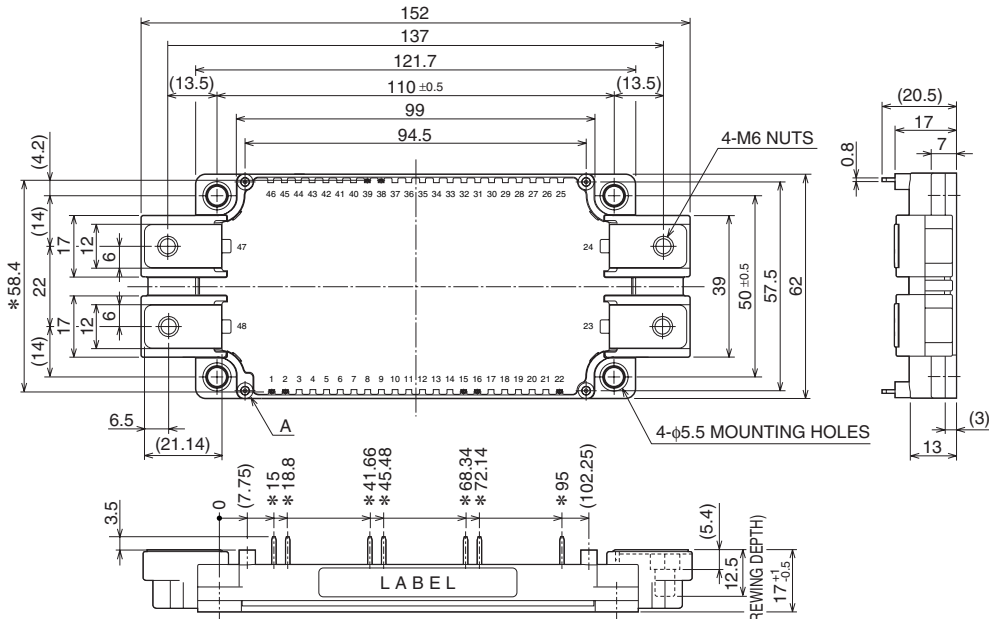

Tolerance otherwise specified

Division of Dimension	Tolerance
0.5 to 3	±0.2
over 3 to 6	±0.3
over 6 to 30	±0.5
over 30 to 120	±0.8
over 120 to 400	±1.2

\* Pin positions with tolerance  $\pm 0.5$

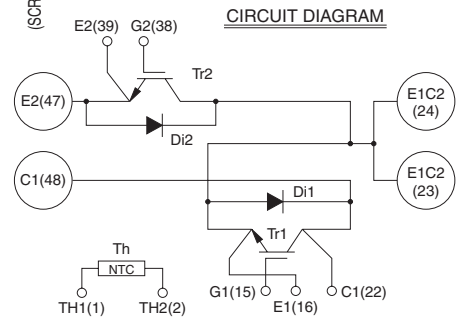

**ABSOLUTE MAXIMUM RATINGS** (Tj = 25°C, unless otherwise specified)

**INVERTER PART**

Symbol	Parameter	Conditions	Rating	Unit
V <sub>CES</sub>	Collector-emitter voltage	G-E Short	1200	V
V <sub>GES</sub>	Gate-emitter voltage	C-E Short	±20	
I <sub>C</sub>	Collector current	DC, T <sub>c</sub> = 90°C (Note. 1)	450	A
I <sub>CRM</sub>		Pulse (Note. 4)	900	
P <sub>C</sub>	Maximum collector dissipation	T <sub>c</sub> = 25°C (Note. 1, 5)	2840	W
I <sub>E</sub> (Note.3)	Emitter current	T <sub>c</sub> = 25°C (Note. 1, 5)	450	A
I <sub>ERM</sub> (Note.3)	(Free wheeling diode forward current)	Pulse (Note. 4)	900	
T <sub>j</sub>	Junction temperature		-40 ~ +150	°C
T <sub>stg</sub>	Storage temperature		-40 ~ +125	
V <sub>iso</sub>	Isolation voltage	Terminals to base plate, f = 60Hz, AC 1 minute	2500	V <sub>rms</sub>
—	Base plate flatness	On the centerline X, Y (Note. 8)	±0 ~ +100	μm
—	Torque strength	Main terminals M6 screw	3.5 ~ 4.5	N·m
—	Torque strength	Mounting M5 screw	2.5 ~ 3.5	
—	Weight	(Typical)	330	g

Note. 8: Base plate flatness measurement point is as in the following figure.

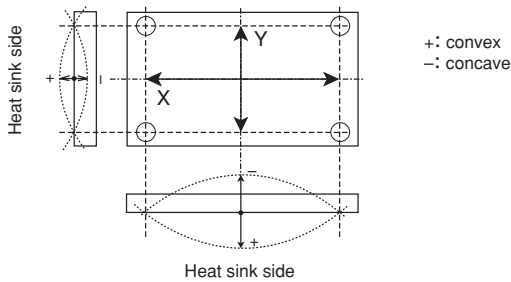

CM450DX-24A

HIGH POWER SWITCHING USE

ELECTRICAL CHARACTERISTICS (Tj = 25°C, unless otherwise specified)

INVERTER PART

Symbol	Parameter	Conditions	Limits			Unit	
			Min.	Typ.	Max.		
ICES	Collector cutoff current	VCE = VCES, VGE = 0V	—	—	1	mA	
VGE(th)	Gate-emitter threshold voltage	IC = 45mA, VCE = 10V	6	7	8	V	
IGES	Gate leakage current	±VGE = VGES, VCE = 0V	—	—	0.5	µA	
VCE(sat)	Collector-emitter saturation voltage	IC = 450A, VGE = 15V (Note. 6)	Tj = 25°C	2.0	2.6	V	
			Tj = 125°C	2.2	—		
		IC = 450A, VGE = 15V	Chip	1.9	—		
Cies	Input capacitance	VCE = 10V VGE = 0V	—	—	68	nF	
Coes	Output capacitance		—	—	5.9		
Cres	Reverse transfer capacitance		—	—	1.4		
QG	Total gate charge	VCC = 600V, IC = 450A, VGE = 15V	—	2000	—	nC	
td(on)	Turn-on delay time	VCC = 600V, IC = 450A	—	—	650	ns	
tr	Turn-on rise time	VGE = ±15V, RG = 0.68Ω	—	—	250		
td(off)	Turn-off delay time	Inductive load	—	—	700		
tf	Turn-off fall time		—	—	600		
trr (Note.3)	Reverse recovery time		—	—	250		
Qrr (Note.3)	Reverse recovery charge	(IE = 450A)	—	14	—	µC	
VEC(Note.3)	Emitter-collector voltage	IE = 450A, VGE = 0V (Note. 6)	—	2.6	3.4	V	
		IE = 450A, VGE = 0V, chip	—	2.5	—		
Rlead	Module lead resistance	Main terminals-chip, per switch	—	0.8	—	mΩ	
Rth(j-c)Q	Thermal resistance	per IGBT	—	—	0.044	K/W	
Rth(j-c)R	(Junction to case) (Note. 1)	per free wheeling diode	—	—	0.078		
Rth(c-f)	Contact thermal resistance (Case to heat sink) (Note. 1)	Thermal grease applied per 1 module (Note. 2)	—	0.015	—		
RGint	Internal gate resistance	per switch	TC = 25°C	1.4	2.0	2.6	Ω
			TC = 125°C	2.8	3.0	5.2	
RG	External gate resistance		0.68	—	6.8		

NTC THERMISTOR PART

Symbol	Parameter	Conditions	Limits			Unit
			Min.	Typ.	Max.	
R	Zero power resistance	TC = 25°C	4.85	5.00	5.15	kΩ
ΔR/R	Deviation of resistance	TC = 100°C, R100 = 493Ω	-7.3	—	+7.8	%
B(25/50)	B constant	Approximate by equation (Note. 7)	—	3375	—	K
P25	Power dissipation	TC = 25°C	—	—	10	mW

Note. 1: Case temperature (TC), heat sink temperature (Tr) measured point is just under the chips. (Refer to the figure of the chip location.)

2: Typical value is measured by using thermally conductive grease of λ = 0.9W/(m·K).

3: Represent ratings and characteristics of the anti-parallel, emitter-collector free wheeling diode (FWDi).

4: Pulse width and repetition rate should be such that the device junction temperature (Tj) dose not exceed Tjmax rating.

5: Junction temperature (Tj) should not increase beyond 150°C.

6: Pulse width and repetition rate should be such as to cause negligible temperature rise.

(Refer to the figure of the test circuit for VCE(sat) and VEC)

$$7: B(25/50) = \ln\left(\frac{R_{25}}{R_{50}}\right) / \left(\frac{1}{T_{25}} - \frac{1}{T_{50}}\right)$$

R25: resistance at absolute temperature T25 [K]; T25 = 25 [°C]+273.15 = 298.15 [K]

R50: resistance at absolute temperature T50 [K]; T50 = 50 [°C]+273.15 = 323.15 [K]

Chip Location (Top view)

Dimensions in mm (Tolerance: ±1mm)

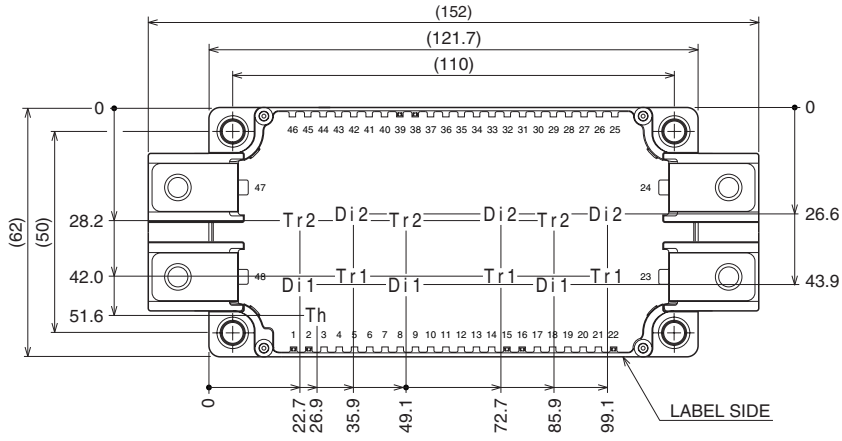

Each mark points the center position of each chip. Tr1/Tr2: IGBT, Di1/Di2: FWDi, Th: NTC thermistor

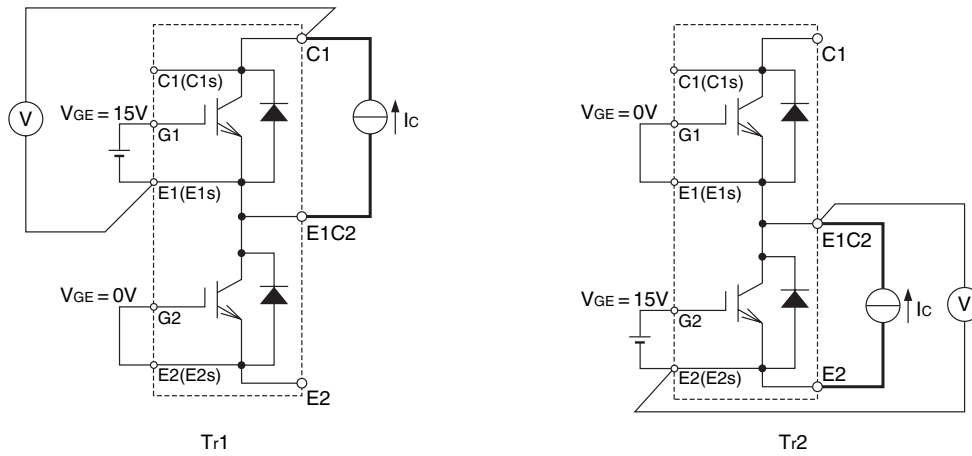

VCE(sat) test circuit

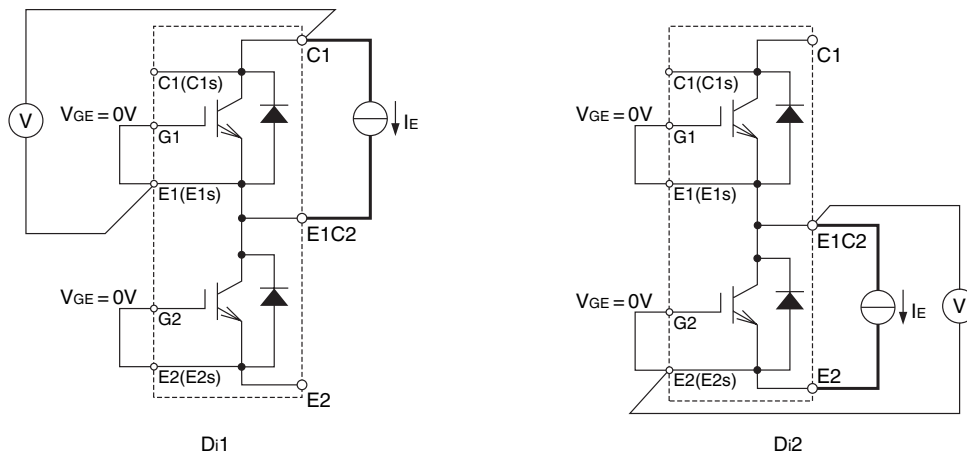

VEC test circuit

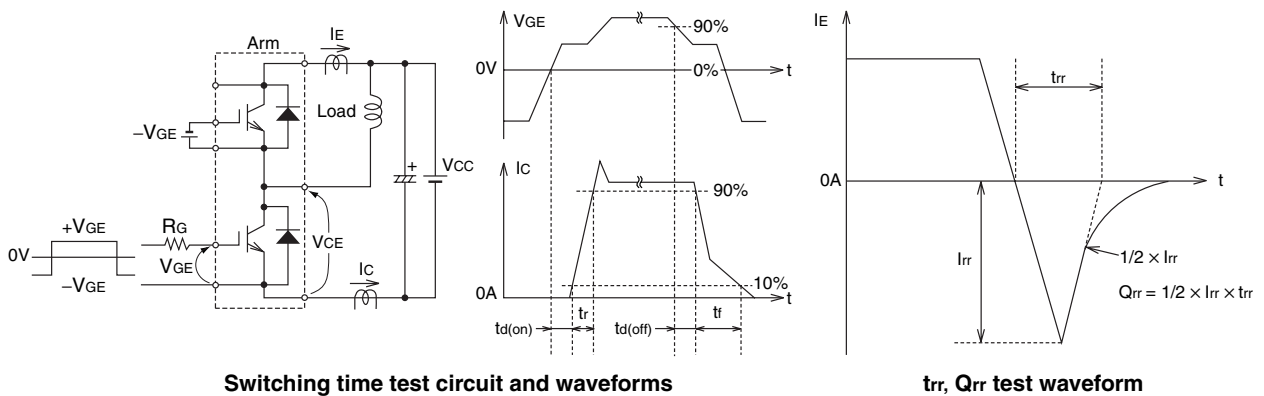

PERFORMANCE CURVES

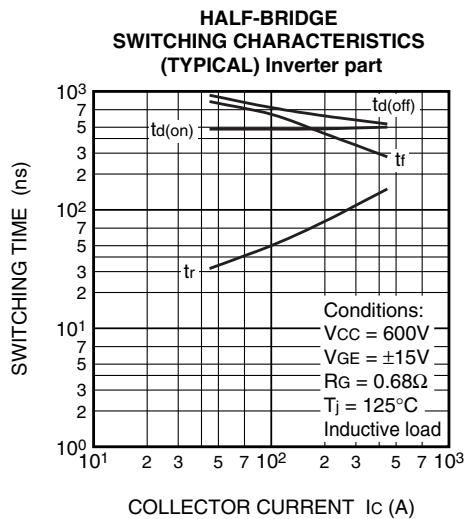
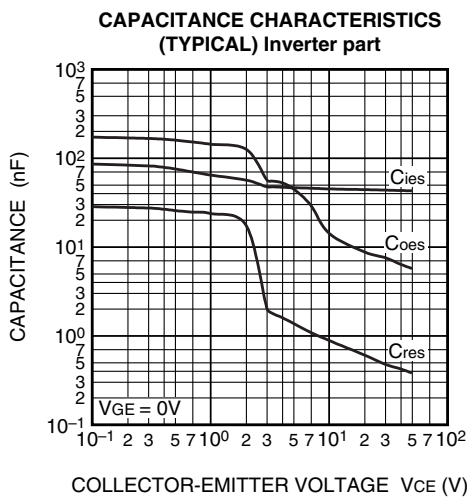
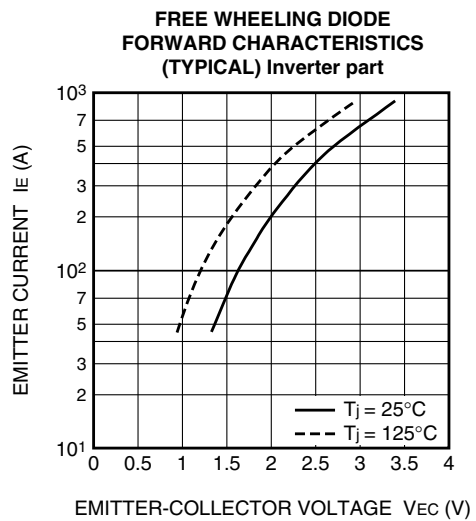
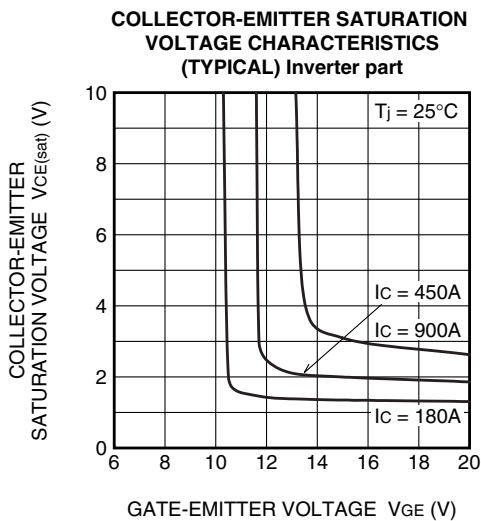
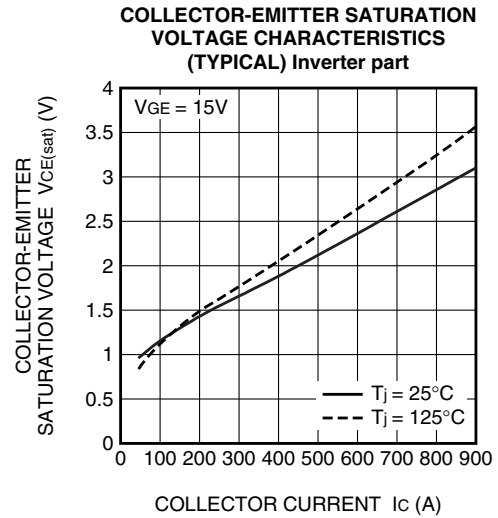
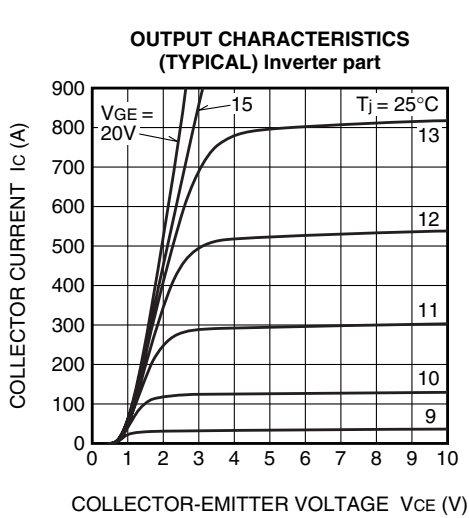

HALF-BRIDGE SWITCHING CHARACTERISTICS (TYPICAL) Inverter part

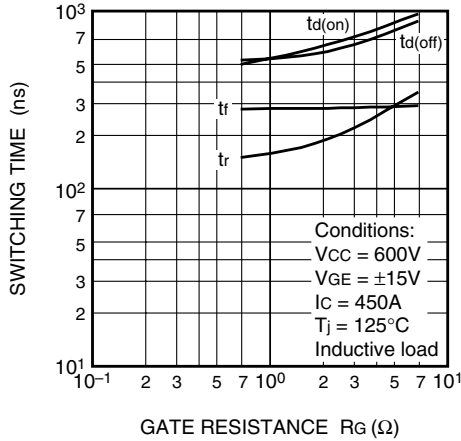

HALF-BRIDGE SWITCHING CHARACTERISTICS (TYPICAL) Inverter part

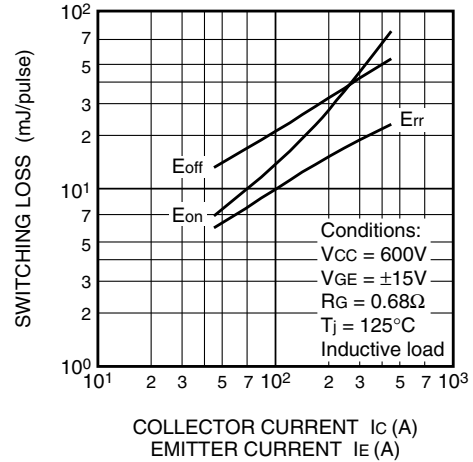

HALF-BRIDGE SWITCHING CHARACTERISTICS (TYPICAL) Inverter part

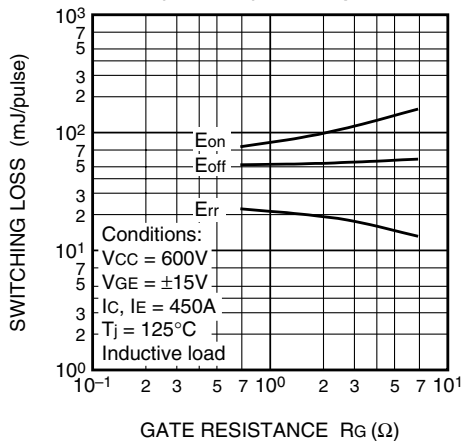

REVERSE RECOVERY CHARACTERISTICS OF FREE WHEELING DIODE (TYPICAL) Inverter part

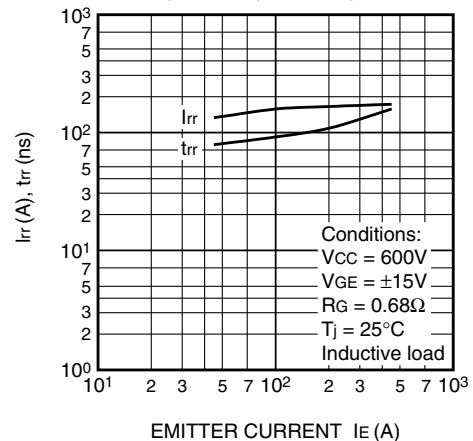

GATE CHARGE CHARACTERISTICS (TYPICAL) Inverter part

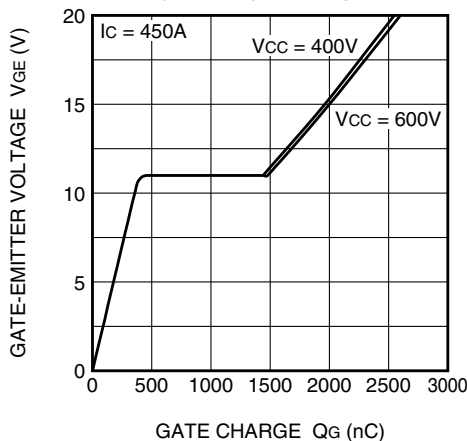

TRANSIENT THERMAL IMPEDANCE CHARACTERISTICS

